

SHUM YIP UPPERHILLS UHPC DUCTAL FO FACADE PANELS ANALYSIS OF THE DESIGN PROCESS

Philips VERNON (1), Michael KU (1), Jean-Marc WEILL (2), Yanni ZHAO (3),

(1) EVERGROW INTERNATIONAL Trad; Co, Ltd, Shanghai, China / e-grow@163.com /

(2) C&E INGENIERIE, Paris, France / weill@ceingenierie.fr /

(3) C&E INGENIERIE, Paris, France / zhao@ceingenierie.fr /

Abstract

This paper has been drawn up in the framework of the construction studies for the UHPFRC panel for Shum Yip Upperhills, built at Shenzhen, in China. The UHPFRC Material used is Organic fibers DUCTAL® FO with local reinforcement. The paper seeks to follow the conceptual design, reconstructing the decision-making process.

Résumé

Cet article a été élaboré dans le cadre des études pour la conception de panneaux BFUP (Shenye Upperhills project), construit à Shenzhen, en Chine. Le matériau utilisé est le BFUP à fibres organiques DUCTAL® FO localement renforcé. L'article propose de reconstituer le processus de conception de la solution technique.

Key words

UHPFRC – DUCTAL – Partially reinforced – Precast– Facade

1 General presentation



Figure 1 : Site view and perspective view of the façade (Source: Urbanus)

The UHPFRC façade panels are designed for Shum Yip Upperhills Loft, a program which includes housing, offices, shopping malls and cultural spaces. The overall project is designed by Urbanus (Shenzhen, China) and the façade is built by the contractor E-Grow (Shanghai, China). The total surface of the curtain wall is more than 20000 m², the dimension of a typical panel is 1.5m (width) x 2.8m (height). The Material used is UHPFRC Organic Fibers DUCTAL NaW3 FO without Thermal Treatment partially reinforced with rebars. The paper wants to present a knowledge engineering approach, reconstructing the decision-making process. The following questions will be discussed:

- **A** How the differences between design objectives and calculation and technological constraints, affect the quality of the object itself?
- **B** What can be a proper coordination among the design stages to achieve high quality with cladding design using Organic Fibers UHPC.

- C What kind of knowledge is used?

2 Organic Fibers Ultra High-Performance Concrete Design process

The Domain of use UHPFRC/Ductal FO is mostly cladding elements, non-structural panels, shaping device, stair tread and eventually stair cases. Due to very few design recommendations the calculation design method applied to define reference stress value for the unreinforced UHPFRC/Ductal FO is characterized as follows:

- Step one: an average tensile bending stress is evaluated from a thin element
- A safety coefficient of 3 is applied on this value on the elastic range.

From this hypothesis, the following behavior curves at Service Limit State can be used:

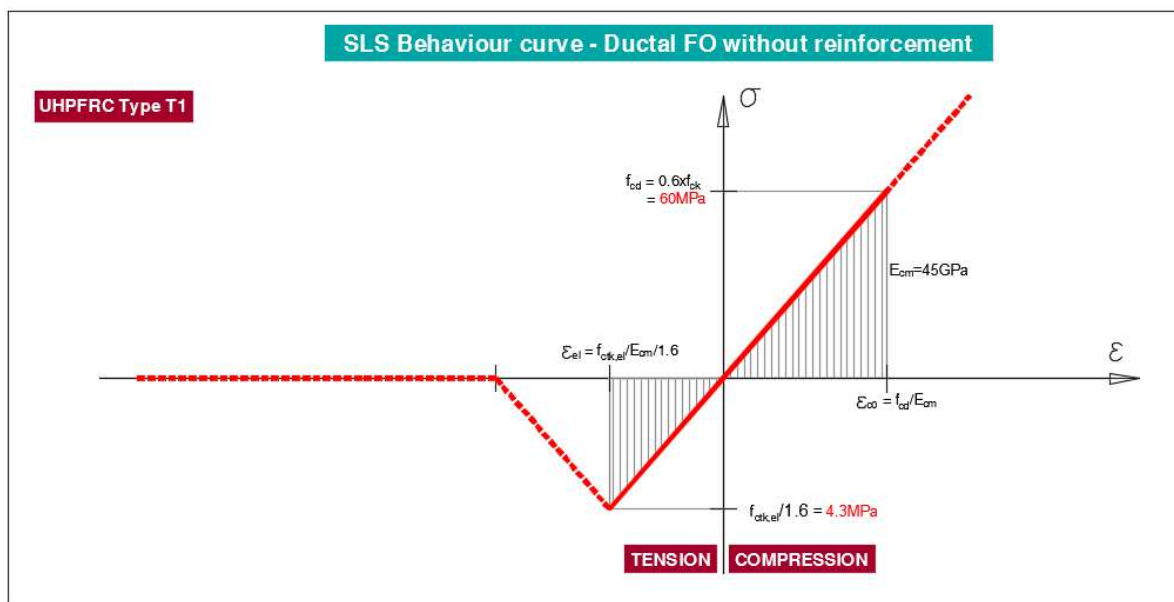

Figure 2 : SLS behavior curve – Ductal FO without reinforcement

When the UHPFRC/Ductal FO is reinforced the behavior curve at the Service Limit State (SLS) is defined with an instantaneous elastic modulus ($E_{cm} = 45000 \text{ MPa}$). The design method is characterized as the followings:

- A linear elastic stage limited by a stress value $f_{ctk, el}$
- A post-cracking stage characterized by a stress-crack width law.
- The verification should be carried out at the Service Limit State and at the Ultimate Limit Service

This approach is stipulated for concrete reinforced with metal fibers in the NF P18-710, which is not the case for UHPFRC/Ductal FO, however, this approach help to develop an understanding of the design rules with a « strain softening law » due to the addition of fibers.

According to the identity card of Ductal NaW3 FO STT, the material follows a strain softening law T1. This method is giving the following behavior curves at Service Limit State and Ultimate Limit State:

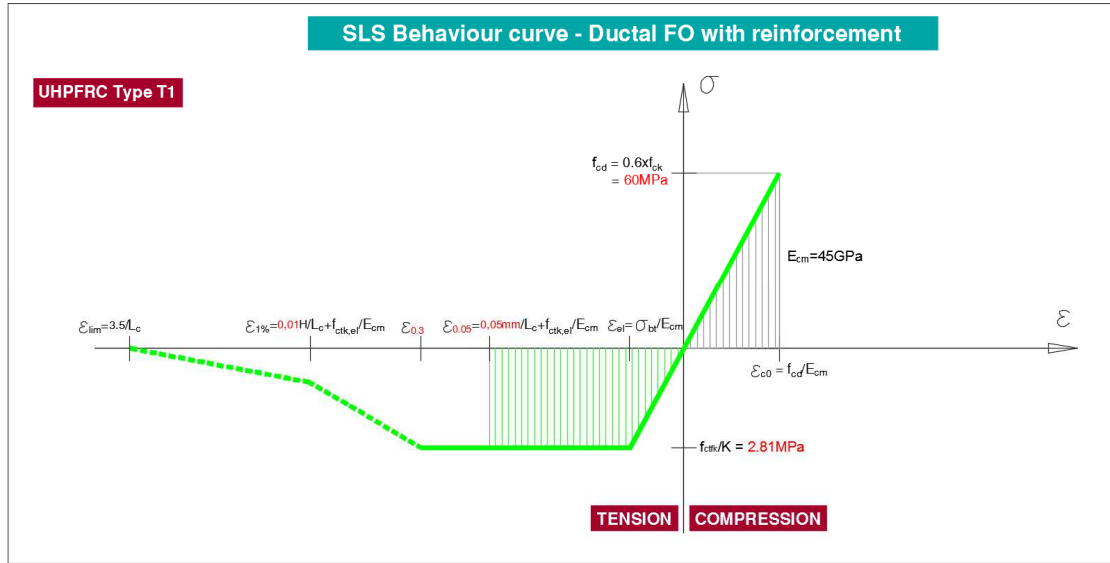

Figure 3 : SLS behavior curve – Ductal FO with reinforcement

The tensile plastic stage is limited to elongation $\epsilon_{(0,05mm)} = 0,05mm/L_C + f_{ctk,el} / E_{cm}$ with $L_C = 2/3 h$ with limitation of crack opening 0.05mm and limitation of compressive strain to $\epsilon_{c0} = 1.33\text{‰}$.

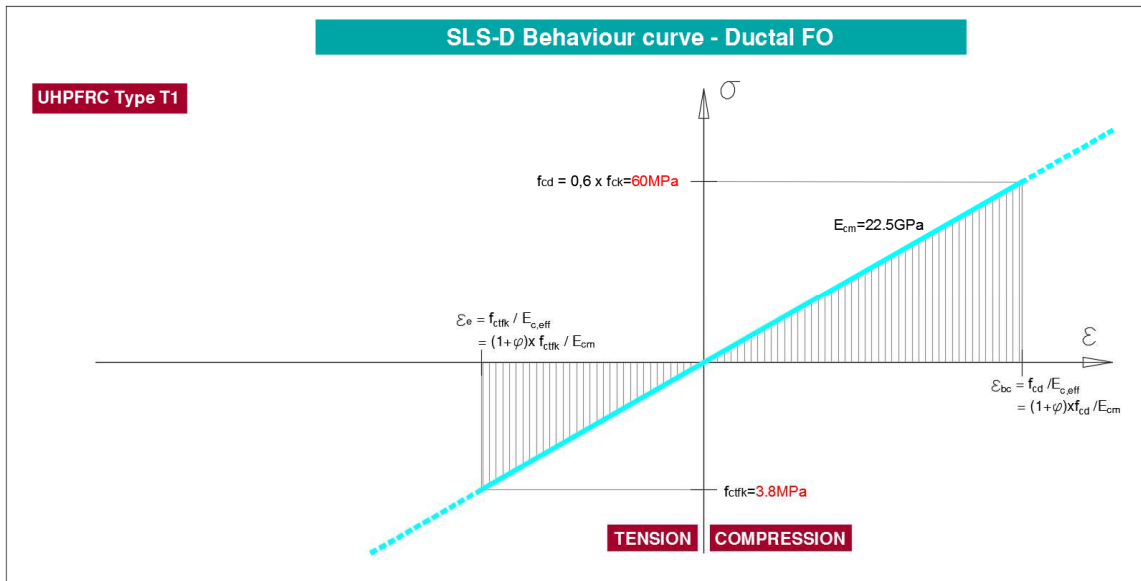

Figure 4 : SLS-D behavior curve – Ductal FO

The behaviour curve at the Service Limit State according to Displacement (**SLS-D**) is established with a delayed elastic modulus ($E_{c,eff} = 22500\text{MPa}$).

The verification takes account of concrete creep by an affine transformation of the behaviour curve according to a coefficient $(1 + \varphi)$, The value recommended by Lafarge for the coefficient φ is 1.0 without heat treatment. The delayed elastic modulus of the DUCTAL[®] FO is divided by 2,0 ($E_{c,eff} = 22500\text{MPa}$) in relation to the instantaneous modulus.

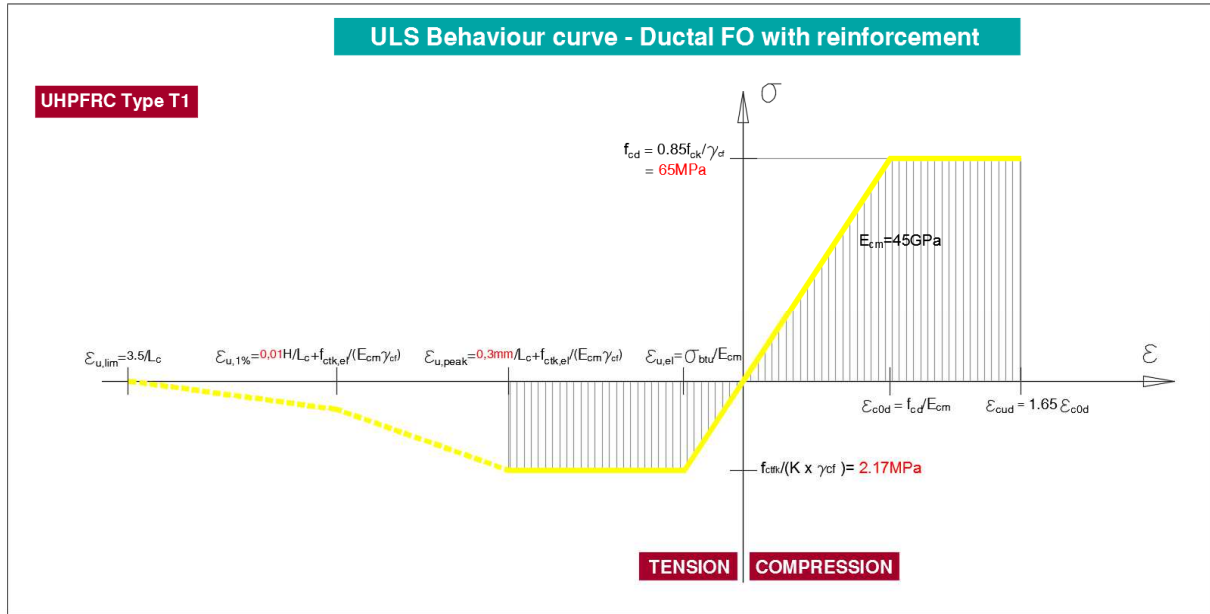

Figure 5 : ULS behavior curve – Ductal FO with reinforcement

The behaviour curve at the ultimate limit state (ULS) is defined with an instantaneous elastic modulus ($E_{cm} = 45000$ MPa). The tensile plastic stage of the DUCTAL[®] FO is limited to elongation: $\varepsilon_{(0,3mm)} = 0,3mm/L_C + f_{ctk,el} / (E_{cm} \times \gamma_{cf}) \leq 10\%$ with $L_C = 2/3 h$ (see NF P18-710 §3.1.7.3). The plastic compressive strain of the DUCTAL[®] FO is limited to $\varepsilon_{cud} = 2.40\%$.

The behavior curves can be understood with the following comments:

- **F1:** For thick element, At the plastic range, the elongation is limited by a factor depending of the height of the element ($2/3 h$). This rough factor is resulting from the observation of the position of the cracking along the element (almost every $2/3h$).
- **F2:** When the thickness of the element is under $3 \cdot L_f$ (thin element) the contribution of the tensioned Ductal can only be taken into account if the tensile deformation along the medium fiber is not greater than $\varepsilon_{u,lim} / 2$
- **F3:** In case shear and tension occur in the same section (continuous beam for example), the designer mustn't take in account two times the same fiber.

Although several methods in the use of UHPC Organic fibers in architectural design have been developed we have compared, for this project UHPFRC FM and FO design process.

The following arguments was analyzed:

- Calculation process
- Technological process
- Construction process

From this analysis, we have developed, for the Shum Yip Upperhills project, a design method for the feasibility and design development stages.

UHPFRC CALCULATION PROCESS / ROUGH SYNTHESIS						
	BENDING ELASTIC ANALYSIS	BENDING POST ELASTIC ANALYSIS	REBAR CONTRIBUTION	SHEAR ANALYSIS	DEFLECTION CONTROL	CRACK CONTROL ANALYSIS
UHPFRC DUCTAL FO	Average tensile bending stress with a safety factor of 3	Using stress crack width law	Depending on the design but this must remain local reinforcement	Considering fibers contribution	Calculation in a non cracked section With a specific material behavior law	Condition of non brittleness
UHPFRC DUCTAL FM	Following Code	Using stress crack width law	Following codes	Considering fibers contribution / section contribution / rebars contribution		

Figure 6 : Rough synthesis of UHPFRC calculation process

UHPFRC TECHNOLOGICAL KEY POINTS / ROUGH SYNTHESIS						
	ENVIRONMENTAL CLASSES	MINIMUM THICKNESS AND WIDTH	PANEL DEAD WIEGHT TRANSFER	REBAR REINFORCEMENT	PANEL ANCHORAGE STRATEGY	HEAT TREATMENT
UHPFRC DUCTAL FO	If using reinforcing Ductal checking covering of rebar	30 mm (poured with no reinforcement) / 35mm (poured with reinforcement) / 15 mm (spraid) / fiber length limit	If possible consider isostatic transfer to the primary structure.	To be used rarely. Cracking risk analysis	Connection systems have to allow both for thermal expansion and fitting tolerane	Rarely used in everyday project
UHPFRC DUCTAL FM		Acceptable and justified solution				

Figure 7 : Rough synthesis of UHPFRC technological key points

UHPFRC CONSTRUCTION PROCESS SPECIFICITIES / ROUGH SYNTHESIS						
	FORMWORK STRATEGY	HEAT TREATMENT	SHRINKAGE QUESTION	CONSTRUCTION STAGE ANTICIPATION	PREFABRICATION VERSUS PULLED ON SITE	UNEXPECTED EVENTS
UHPFRC DUCTAL FO	Complexity of the molds / number and repetition of the molds	Ralely used in everyday projects / depending of the dimension and contractof capacity	0.8 mm/m. Almost all the shrinkage at the beguinning	The anchorage used for construction stage must be different. The construction step must be checked with the contractor	Only prefabrication.	Deflexion during molded process / unexpected cracking near reinforcement
UHPFRC DUCTAL FM			0.5 mm/m. Almost all the shrinkage at the beguinning			Prefabrication and pulled on site for specific structural element

Figure 8: Rough synthesis of UHPFRC construction process specificities

3 Feasibility study design stage

To cross the specificity of the material (included the anchorage question) and the design the feasibility stage includes:

- 1- Choice of material regarding the subject
- 2- Geometrical strategy
- 3- Supports strategy
- 4- Design risk regarding crack analysis
- 5- Construction process strategy
- 6- Preliminary calculation
- 7- Synthesis

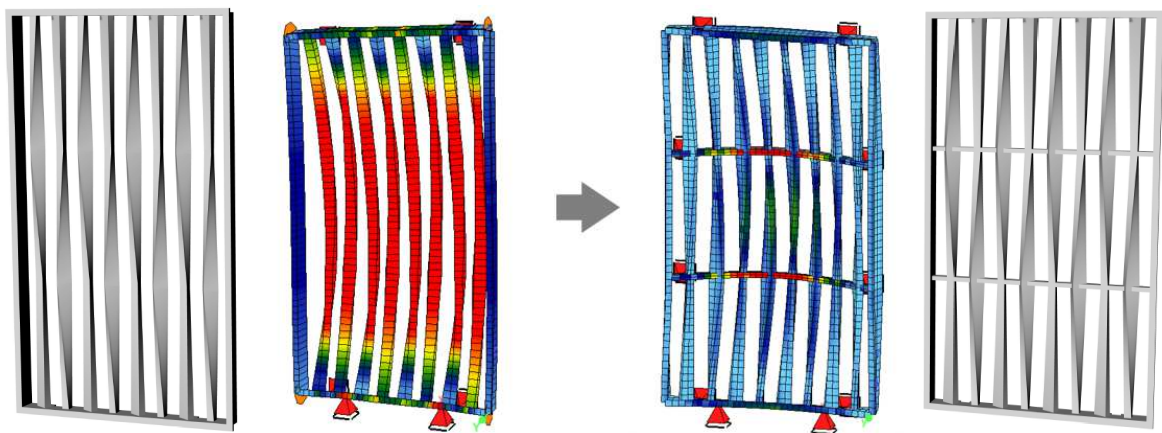

Figure 9: Deflection analysis of two solutions during the feasibility study stage

The initial design proposed by the design team was considering a peripheral frame and twisted interior independent vertical elements. It is important to precise that, regarding the specific condition of the building site, the panel must be designed for extreme wind load (extreme value of 2.6 kN/m^2), thermal loads and seismic action.

From a structural point of view, the twisted shape and the slenderness of each vertical components make the entire system more susceptible and vulnerable to the lateral load (especially the wind load and seismic action).

Moreover, the disassociation of each vertical element, which characterize the initial design (Fig.9-Left) is not efficient specially because of the rotation of the inertia due to Architectural design. As a result, we have proposed, at this stage two additional reinforced horizontal sections at the end of the feasibility study stage.

The model is then calculated with the following two steps:

- 1 / Linear analysis for UHPFRC/Ductal FO sections
- 2 / Nonlinear analysis for UHPFRC/Ductal FO sections with reinforcement.

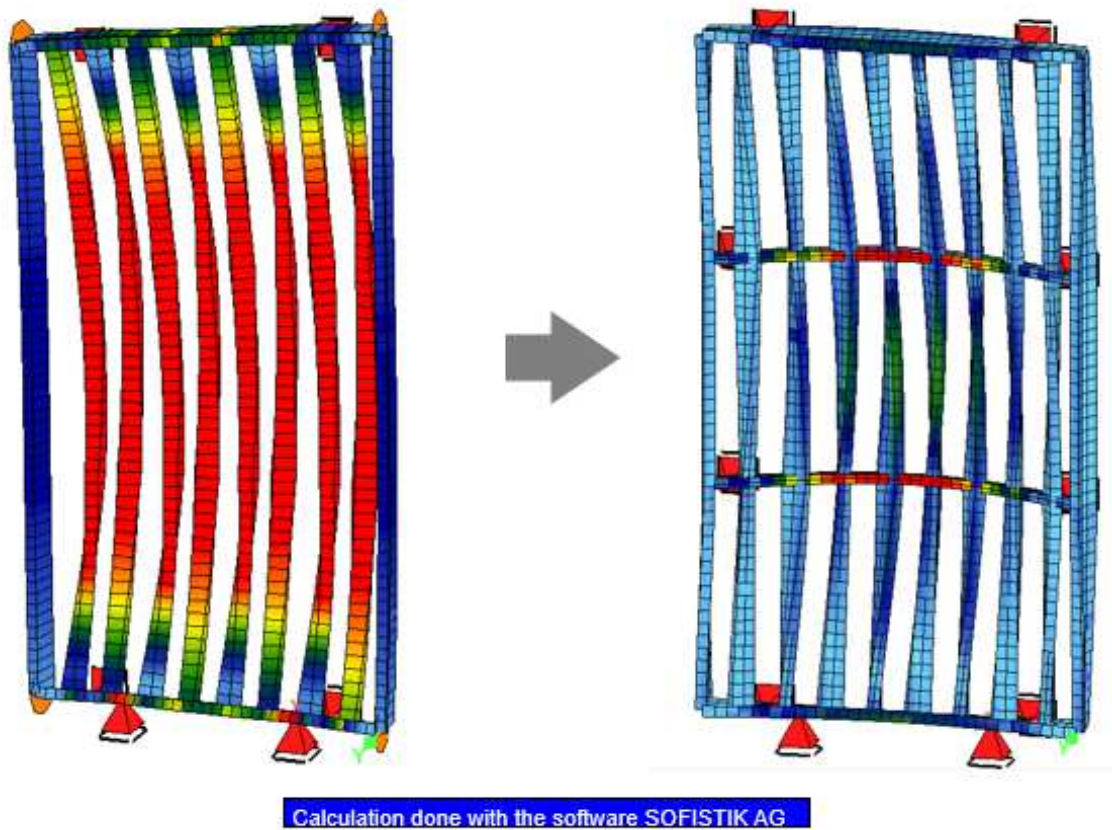

Figure 10: Deflection analysis of two solutions during the feasibility study stage

4 Design development

The Structural analysis done during the design development is realized combining UHPFRC/Ductal FO without reinforcement and with local reinforcement. The unreinforced section of Ductal FO should conform to the following criteria under service limit state:

- Maximum compressive stress $\sigma_{bc} \leq 0,6 \times f_{ck} = 60 \text{ MPa}$
- Maximum tensile stress $\sigma_{bt} \leq f_{ctk,el} / 1.6 = 4.3 \text{ MPa}$ (Value from the ID card of Lafarge)
- The opening of cracks was prohibited by limiting the tensile stress at the elastic stage of the behavior curve.

The Reinforced sections of Ductal FO should conform to the following criteria under service limit state

- Maximum compressive stress $\sigma_{bc} \leq 0,6 \times f_{ck} = 60 \text{ MPa}$
- Maximum tensile stress $\sigma_{bt} \leq f_{ctfk} / K_{global} = 2.81 \text{ MPa}$ (Limit of plastic stage of the behavior curve)
- The opening of cracks in the sections is controlled by limiting the elongation in the behavior curve. (Figure 4)
- Limit of deflection $w_{tot} \leq l / 500$

Under ultimate limit state

- Maximum compressive stress $\sigma_{bc} \leq 0.85 \times f_{ck} / \gamma_{bf} = 65 \text{ MPa}$

- Maximum tensile stress $\sigma_{bt} \leq f_{ctfk} / (K_{global} \cdot \gamma_{cf}) = 2.17 \text{ MPa}$
- Maximum shear stress $V_{Ed} \leq V_{Rd,c} + V_{Rd,f} = \frac{0.24}{\gamma_{cf} \gamma_E} k f_{ck}^{1/2} b_w z + \frac{b_w z \cdot \sigma_{Rd,f}}{\tan \theta}$

with $\gamma_{cf} \gamma_E = 1.5$ and $\tan \theta = 1$

$$\sigma_{Rd,f} = \frac{1}{K_{Local} \times \gamma_{cf} \times w_{0,3}} \int_0^{w_{0,3}} \sigma_{(w)} dw = \frac{\sigma_{(w_{0,3})}}{K_{Local}} = 2.11 \text{ MPa}$$

b_w is the smallest width of the cross-section in the tensile area [m]

z is the inner lever arm.

The structure is modeled by beam elements. Connections between interior vertical elements and peripheral frame are fixed (the reinforcements are continuous). Connections between ribbons of peripheral frame are fixed as well. The finite element analysis is done with the software SOFISTIK®, using the modules ASE (General Static Analysis of Finite Element Structures), AQB (Design of cross section). The iterative calculation takes in account the geometrical non-linearity (2nd order) and the material non-linearity with the behavior law described in section 2. The geometry of the panel is defined as followed:

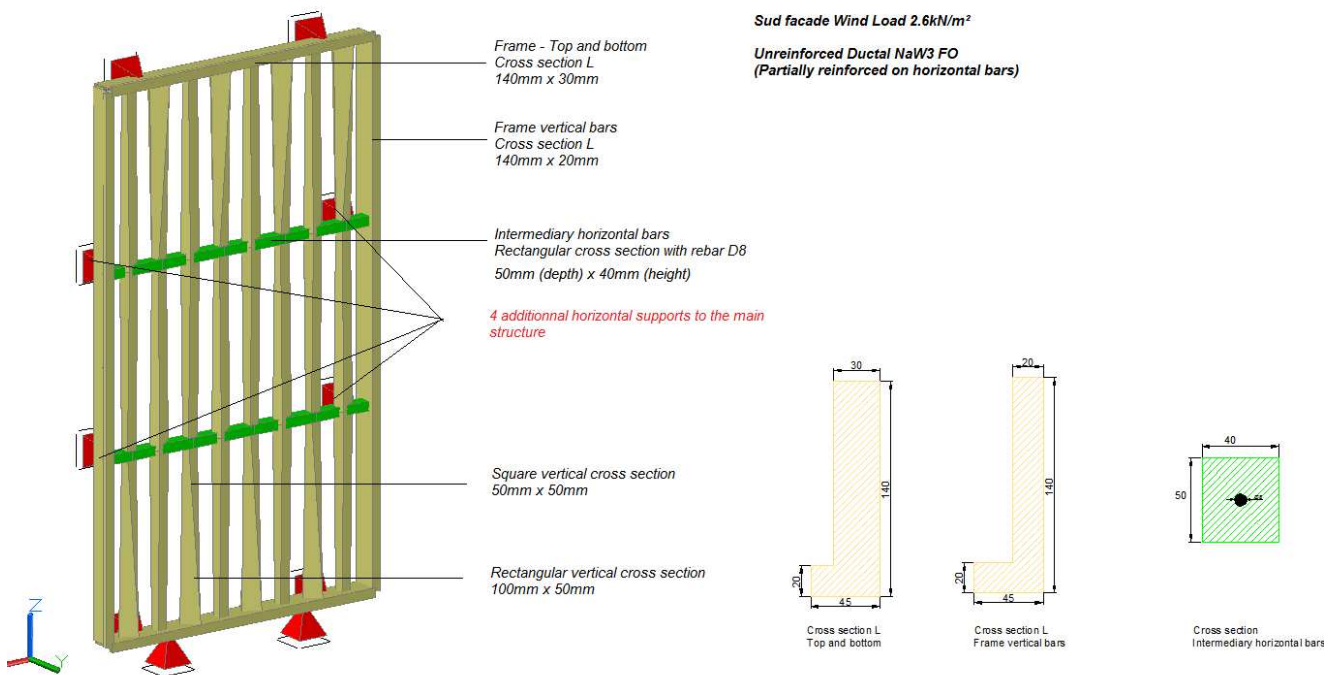

Figure 11: Cross sections

Concerning the Service limit state (SLS): the stress in the UHPC Ductal are lower than the utilization limits described in section §2. The distribution of stress in the cross-section shown in the graphic result of Sofistik is linear as defined in the design hypothesis.

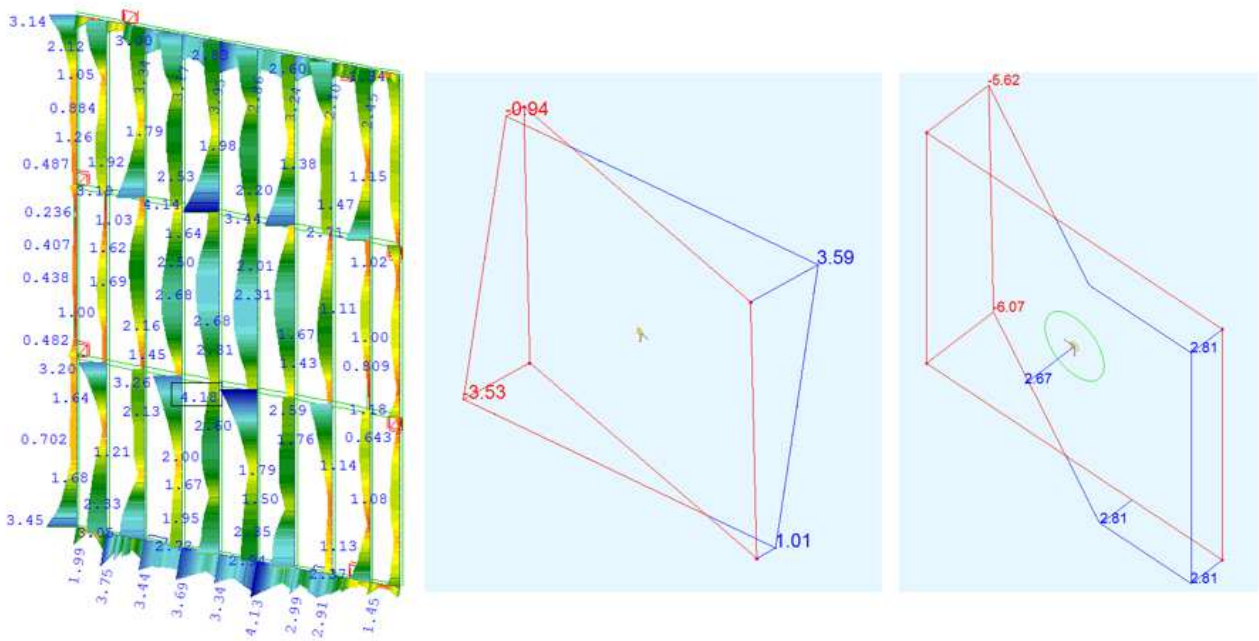

Figure 12 : From left to right: Maximum tensile stress under SLS combination on unreinforced cross-section $< 4.3\text{MPa}$ / Linear axial stress distribution of Unreinforced cross-section - SLS / Non-linear axial stress distribution of Reinforced cross-section - SLS

The crack opening is controlled by limiting the elongation at $\epsilon_{(0,05\text{mm})} = 0,05\text{mm}/L_C + f_{ctk,el} / E_{cm} = 0.604\text{‰}$ on the behaviour curve.

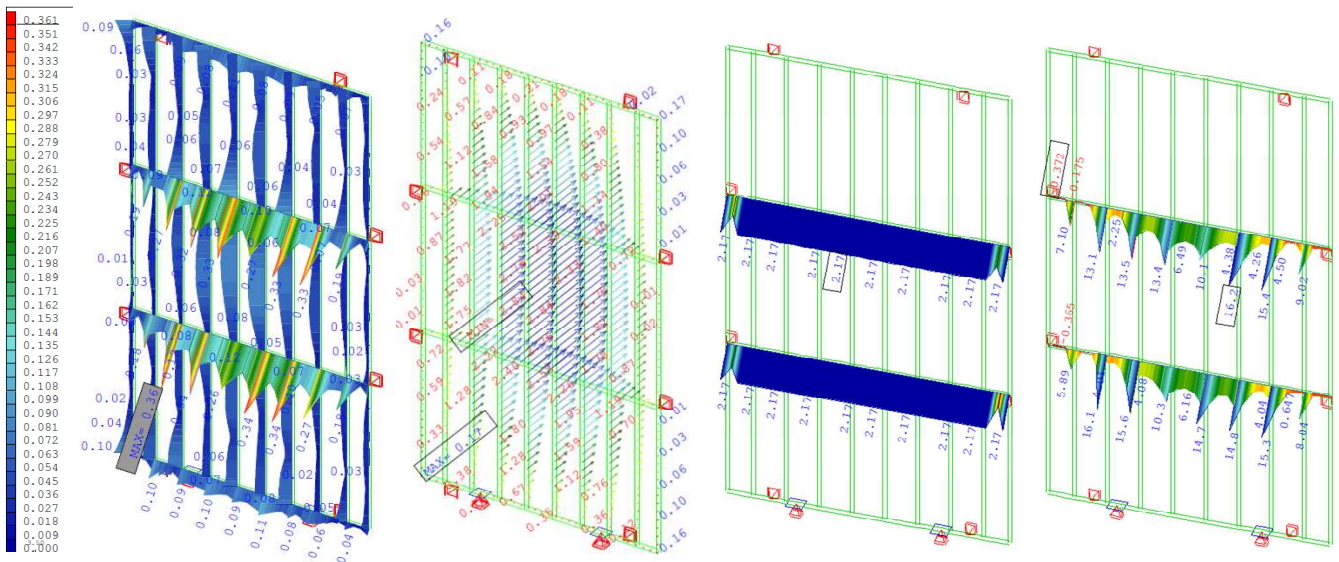

Figure 13: From left to right: Maximum elongation under SLS combination $< 0.604\text{‰}$ / Maximum displacement under SLS combination $< L/500=5.6\text{mm}$ / Maximum tensile stress and maximum compressive stress in reinforcement under ULS combination

5 Construction process by injection moulding

The injection moulding system has been used for the panel construction process. it leads to the generation of extruded geometries.

These geometries are obtained from a linear wire-frame network. The injection molds must, of necessity, be watertight. Thus, they have at least one removable side in order to install the horizontal rebars.

The entire façade can thus be created with a very few number of mold.



Figure 14: Construction process from Ever Grow Ltd

6 Conclusion

The last decade has seen an expansion of facades with complex geometries. The UHPFRC façade panels are designed for Shum Yip Upperhills Loft, is an example of complex geometrical panel design combining a geometry with a locally reinforced UHPFRC Organic Fibers DUCTAL NaW3 FO STT. This project was an opportunity to compare UHPFRC FO and FM design process and to try to define a particular design process with local rebars.

7 Acknowledgment

We would like to give special thanks to the following people and organizations who have acted as key partners for the development of this innovative project: Sebastien Bernardi and Romain Delpont **Lafarge-Holcim** / Included in the **C&E Ingénierie** Design Team Simon Lods

8 Reference

Rationalization of complex shapes façades by Raphael Fabbri and Dominique Corvez / UHPFRC 2013.

Eurocode 2: Calcul des structures en béton de fibres métalliques / 2016 /

NF EN 13 369 : Règles communes pour les produits préfabriqués en béton (Juillet 2006)

Lafarge Holcim : Fiche de caractéristiques techniques du BFUP NaW3-FO Blanc